

## Description

The principle of gas discharge is used not only for overvoltage protection but also in switching applications. Unlike surge arresters, switching spark gaps are active components that work reliably even after igniting hundreds of thousands of times.

2RK-5 series Switching Spark Gaps(SSG) can be used in all applications where high voltage pulses are generated, for example to ignite modern high-pressure gas discharge lamps such as xenon lamps in automotive headlights. Ignition performance is determined to a large degree by the properties of the switching component. An extremely fast switch is called for, which operates virtually without loss and with high insulation resistance in the non-conducting state. It should also be as compact as possible, rugged, highly reliable, and capable of operating over a wide temperature range.

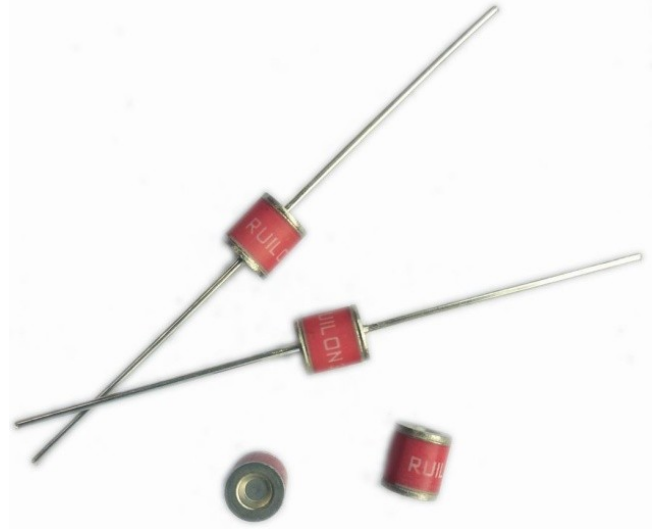

## Features

- I Extremely long life time
- I Stable performance over life
- I Insensitive performance against variations in temperature
- I Low switching losses
- I Very short breakdown time
- I High reliability by robust design
- I Lead-free compliant
- I RoHS and REACH compliant
- I Non-Radioactive

## Applications

- I Igniters for architectural and automotive Xenon discharge lamps
- I Electronic igniters for gas heating and gas domestic appliances, e.g., cookers
- I Ignition of ultra-high pressure gas discharge lamps for data and video projectors

## Part Number Code

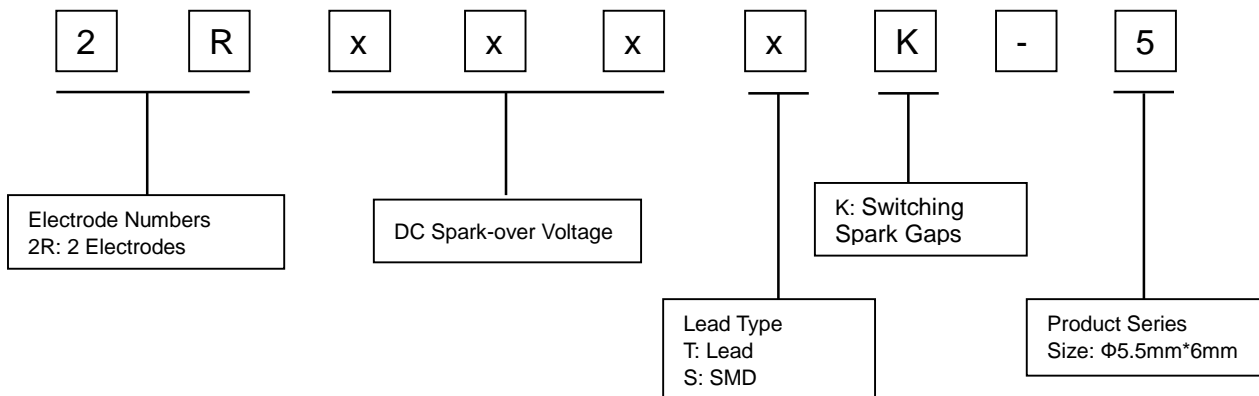

## Electrical Characteristics

Part Number	DIP	2R230TK-5	2R250TK-5	2R300TK-5	2R350TK-5
	SMD	2R230SK-5	2R250SK-5	2R300SK-5	2R350SK-5
<b>Initial Values</b>					
Static Breakdown Voltage $V_s$ @100V/S <sup>1)</sup>					
First ignition Value after 24 hours in darkness		<275 V	<300 V	<360 V	<420 V
Following Ignition Values		207~253 V	225~275 V	270~330 V	315~385 V
<b>Electrical Life Time</b>					
Breakdown Voltage $V_B$ <sup>2)</sup>					
First ignition Value after 24 hours in darkness		<285 V	<310 V	<370 V	<435 V
Following Ignition Values		196~265 V	215~290 V	255~350 V	300~405 V
Switching Operations @ +25°C		$10^5$	$10^5$	$10^5$	$10^5$
Breakdown Time		<50 ns	<50 ns	<50 ns	<50 ns
Maximum Switching Frequency		100 Hz	100 Hz	200 Hz	200 Hz
<b>Test Circuit Parameters</b>					
Open Circuit Voltage $V_0$		230 V <sub>AC</sub>	350 V	400 V	450 V
Loading Resistance $R$		15 K $\Omega$	10 K $\Omega$	10 K $\Omega$	10 K $\Omega$
Discharge Capacitance $C$		2.2 $\mu$ F	680 nF	680 nF	680 nF
Inductance $L$		10 $\mu$ H	0.5 $\mu$ H	0.5 $\mu$ H	0.5 $\mu$ H
Discharge Peak Current $I_P$		~300 A	~500 A	~500 A	~500 A

Part Number	DIP	2R380TK-5 <sup>3)</sup>	2R400TK-5	2R450TK-5	2R470TK-5
	SMD	2R380SK-5 <sup>3)</sup>	2R400SK-5	2R450SK-5	2R470SK-5
<b>Initial Values</b>					
Static Breakdown Voltage $V_s$ @100V/S <sup>1)</sup>					
First ignition Value after 24 hours in darkness		<460 V	<480 V	<540 V	<560 V
Following Ignition Values		350~420 V	360~440 V	405~495 V	423~517 V
<b>Electrical Life Time</b>					
Breakdown Voltage $V_B$ <sup>2)</sup>					
First ignition Value after 24 hours in darkness		<460 V	<500 V	<560 V	<585V
Following Ignition Values		330~440 V	340~460 V	385~515 V	400~540 V
Switching Operations @ +25°C		$10^5$	$10^5$	$10^5$	$10^5$
Breakdown Time		<50 ns	<50 ns	<50 ns	<50 ns
Maximum Switching Frequency		200 Hz	200 Hz	200 Hz	200 Hz
<b>Test Circuit Parameters</b>					
Open Circuit Voltage $V_0$		500 V	520 V	580 V	600 V
Loading Resistance $R$		10 K $\Omega$	10 K $\Omega$	10 K $\Omega$	10 K $\Omega$
Discharge Capacitance $C$		680 nF	680 nF	680 nF	680 nF
Inductance $L$		0.5 $\mu$ H	0.5 $\mu$ H	0.5 $\mu$ H	0.5 $\mu$ H
Discharge Peak Current $I_P$		~500 A	~500 A	~500 A	~500 A

## Switching Spark Gaps (SSG)

## 2RK-5 Series

Part Number	DIP	2R500TK-5	2R550TK-5 <sup>4)</sup>	2R600TK-5
	SMD	2R500SK-5	2R550SK-5 <sup>4)</sup>	2R600SK-5
<b>Initial Values</b>				
Static Breakdown Voltage $V_S$ @100V/S <sup>1)</sup>				
First ignition Value after 24 hours in darkness		<600 V	<680 V	<720 V
Following Ignition Values		450~550 V	510~630 V	540~660 V
<b>Electrical Life Time</b>				
Breakdown Voltage $V_B$ <sup>2)</sup>				
First ignition Value after 24 hours in darkness		<625 V	<710 V	<750 V
Following Ignition Values		425~575 V	485~655 V	510~690 V
Switching Operations @ +25°C		$10^5$	$10^5$	$10^5$
Breakdown Time		<50 ns	<50 ns	<50 ns
Maximum Switching Frequency		200 Hz	200 Hz	200 Hz
<b>Test Circuit Parameters</b>				
Open Circuit Voltage $V_0$		630 V	720 V	750 V
Loading Resistance $R$		13 K $\Omega$	13 K $\Omega$	13 K $\Omega$
Discharge Capacitance $C$		470 nF	470 nF	470 nF
Inductance $L$		0.1 $\mu$ H	0.1 $\mu$ H	0.1 $\mu$ H
Discharge Peak Current $I_P$		~600 A	~600 A	~600 A
<b>Insulation Resistance @100 V</b>		> $10^8 \Omega$		
<b>Capacitance @1MHz</b>		<1 pF		
<b>Marking, red negative</b>		<b>XXXX Y</b> xxx -Nominal voltage K -Switching Spark Gaps X -Year of production		
<b>Weight</b>		DIP ~0.82g SMD ~0.55g		
<b>Operation and storage temperature</b>		-40~+125°C		
<b>Surface treatment</b>		DIP -Nickel Plated SMD -Matte-tin plated		

<sup>1)</sup> At delivery AQL 0.65 level II, DIN ISO 2859

<sup>2)</sup> Fig. 1

<sup>3)</sup> 350 Marking

<sup>4)</sup> 600 Marking

### Test Circuit Fig. 1

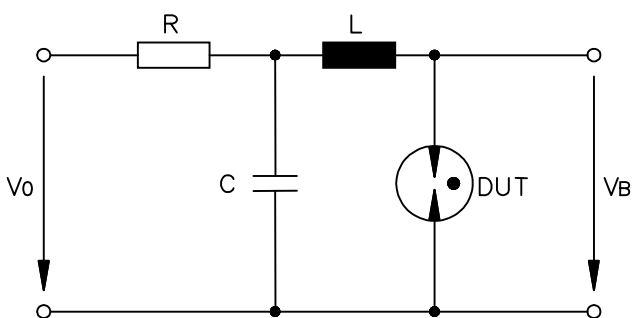

DUT Device Under Test  
 $V_B$  Breakdown Voltage  
 $V_0$ ,  $R$ ,  $L$  and  $C$  Parameters See above table

**Dimensions (Unit: mm/inch)**

**DIP Series (2RxxxTK-5)**

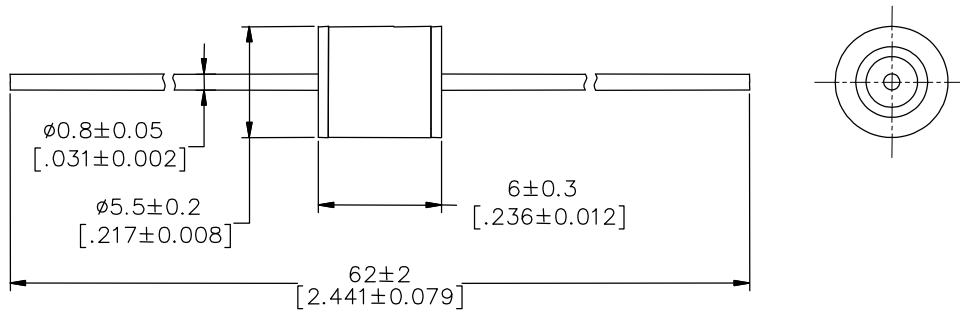

**SMD Series (2RxxxSK-5)**

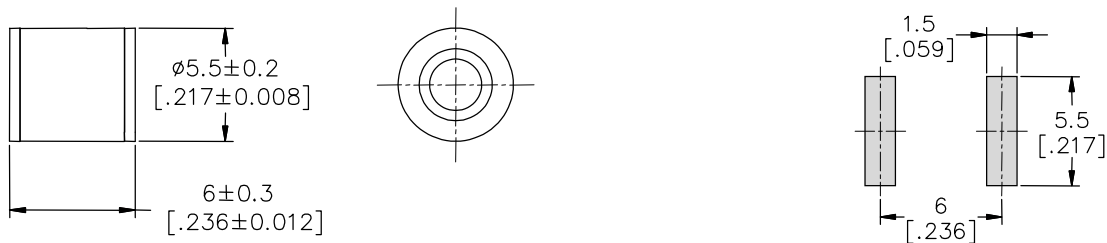

Recommended Soldering Pad Layout

**Packaging Information (Unit: mm/inch)**

**Axial Packaging (Bulk)**

**Plastic Tray**

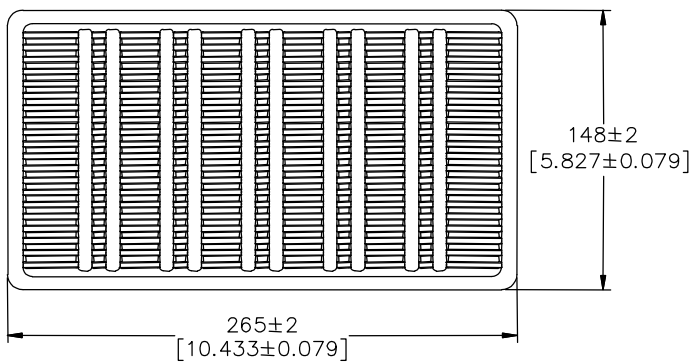

**Inner box**

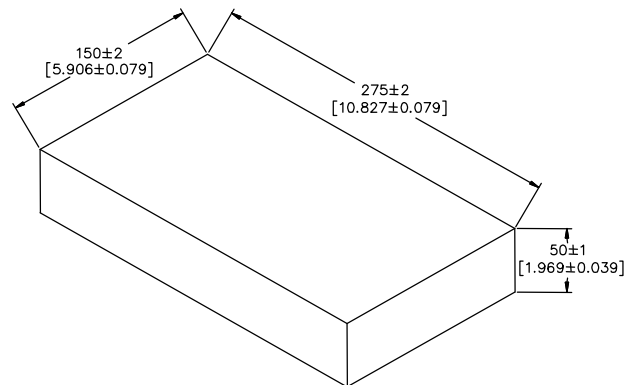

**Packaging Quantity:**

100 PCS per Plastic Tray

5 Plastic Trays per inner box

500 PCS per inner box

Axial Packaging (Tape & Reel)

Tape

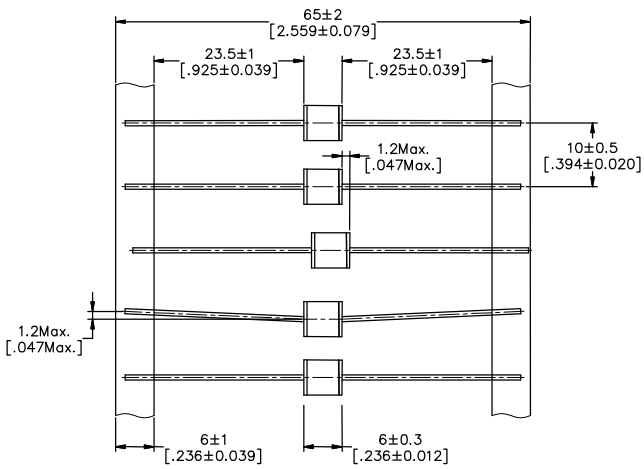

Reel

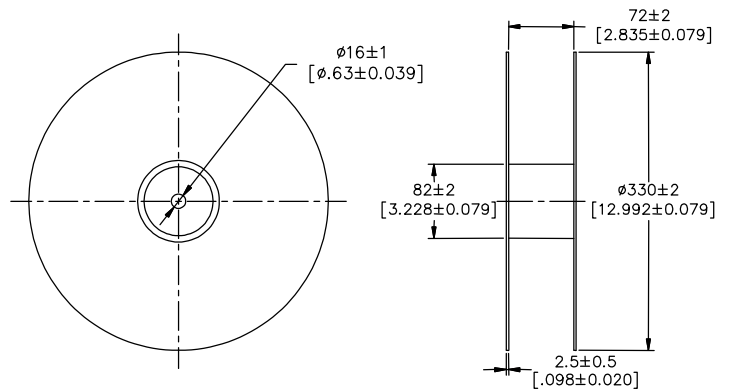

Packaging Quantity:

1000 PCS per reel

SMD Packaging (Tape & Reel)

Tape

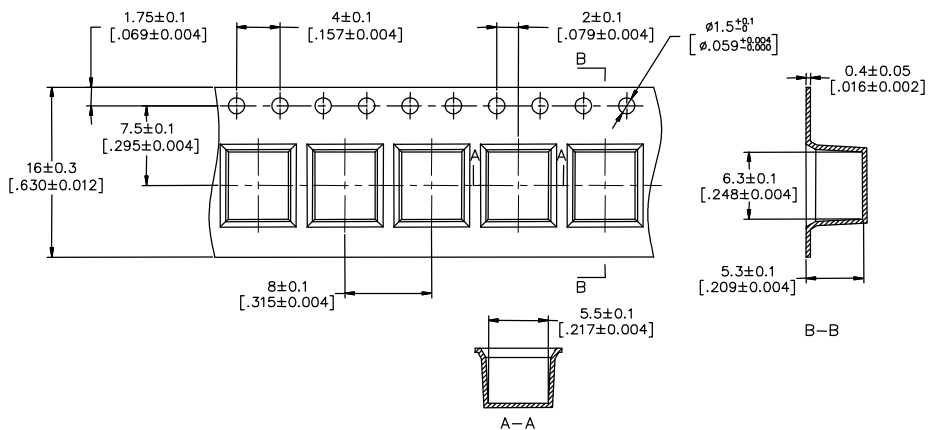

Reel

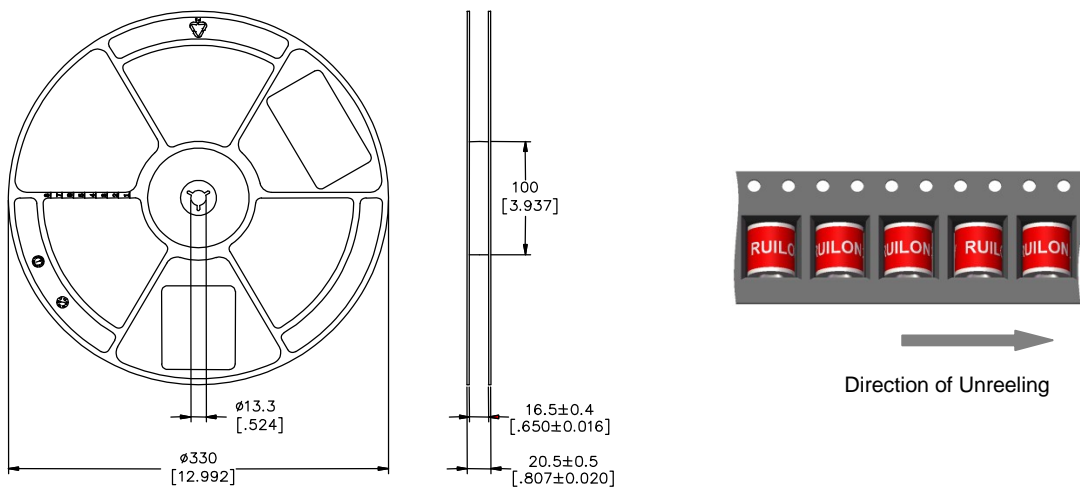

Inner box

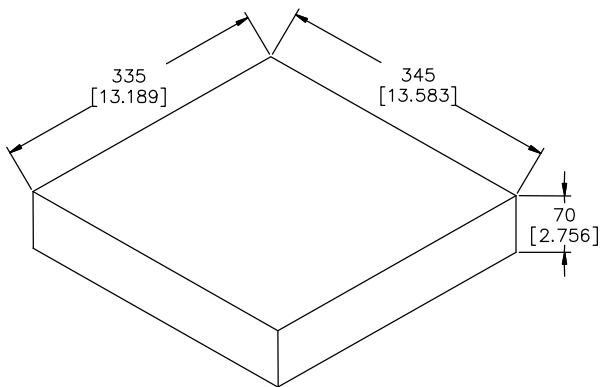

**Packaging Quantity:**

1,000 PCS per reel (13")

3 reels per inner box

3,000 PCS per inner box

**Basic Application Circuit**

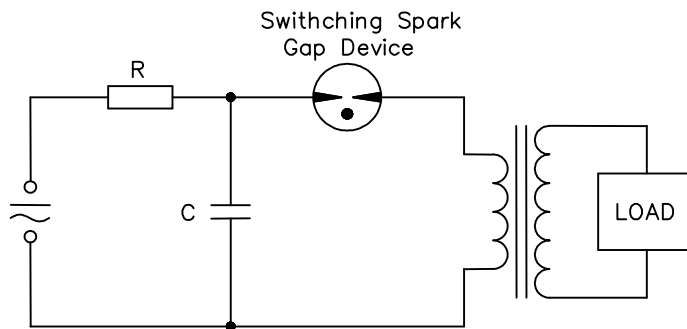

**Soldering Parameters - Wave soldering (Thru-Hole Devices)**

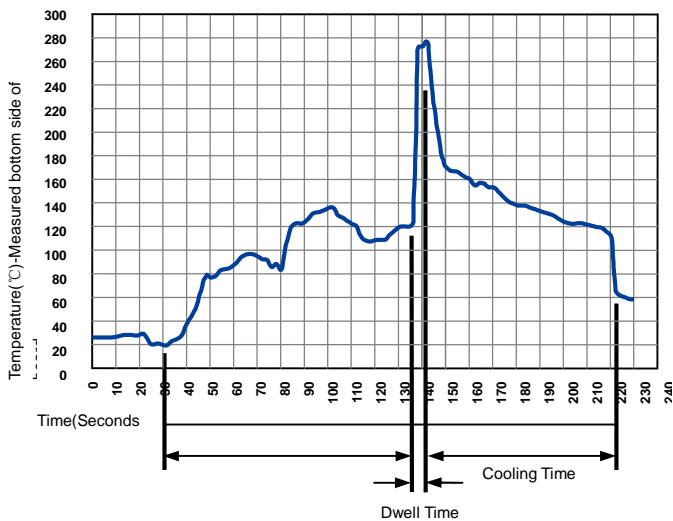

Wave Soldering Condition		Pb-Free assembly
Preheat	Temperature Min	100°C
	Temperature Max	150°C
	Time (Min to Max)	60-180 Seconds
Solder Pot Temperature		280°C Max
Solder Dwell Time		2-5 Seconds

**Soldering Parameters - Reflow Soldering (Surface Mount Devices)**

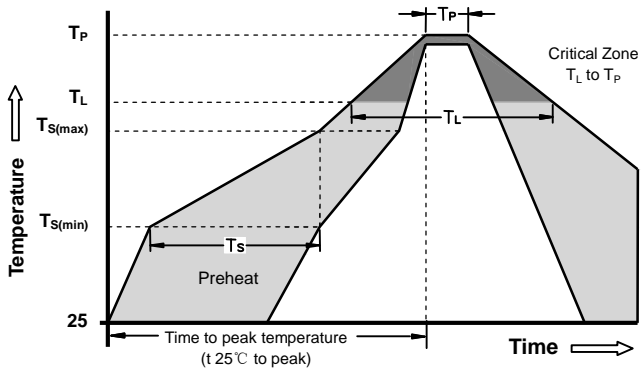

Reflow Condition		Pb - Free assembly
Preheat	- Temperature Min ( $T_{s(min)}$ )	150°C
	- Temperature Max ( $T_{s(max)}$ )	200°C
	- Time (min to max) ( $t_s$ )	60 -180 Seconds
Average ramp up rate ( Liquids Temp $T_L$ to peak		3°C/second max
$T_{s(max)}$ to $T_L$ - Ramp-up Rate		5°C/second max
Reflow	- Temperature ( $T_L$ ) (Liquids)	217°C
	- Time (min to max) ( $t_s$ )	60 -150 Seconds
Peak Temperature ( $T_P$ )		260 +0/-5°C
Time within 5°C of actual peak Temperature ( $t_p$ )		10 - 30 Seconds
Ramp-down Rate		6°C/second max
Time 25°C to peak Temperature ( $T_P$ )		8 minutes Max
Do not exceed		260°C